

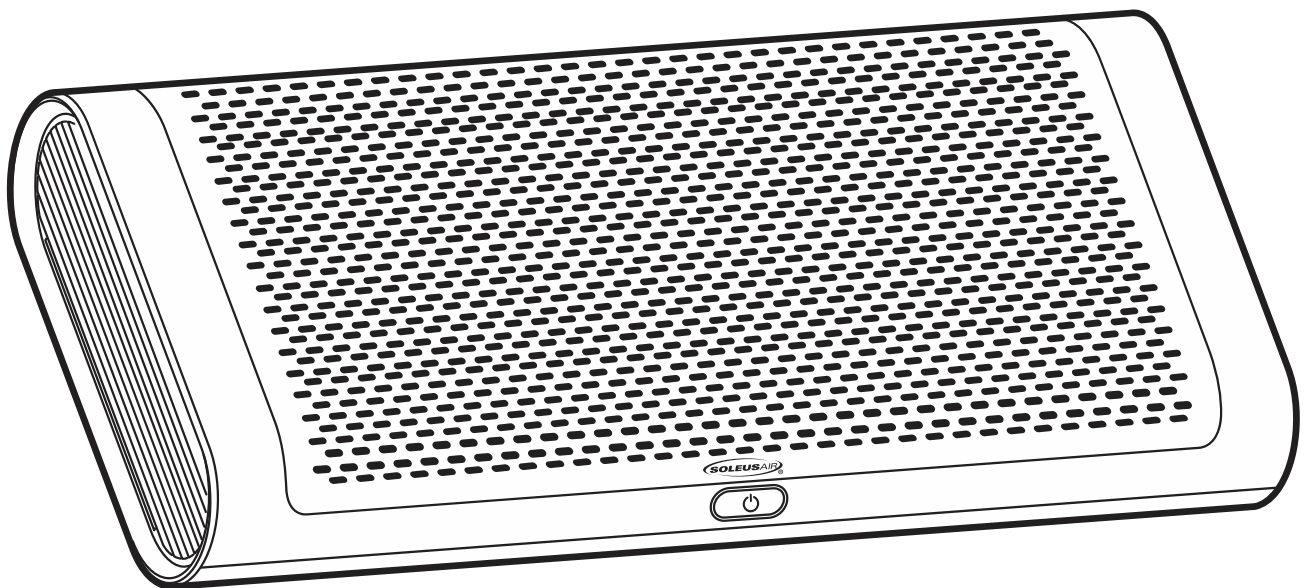

Car Air Purifier

OPERATING INSTRUCTIONS



KJ60F-C01

PURCHASE INFORMATION

Thank you for choosing a Soleus Air Car Air Purifier. This Owner's Manual will provide you with valuable information necessary for the proper care and maintenance of your new product. Please take a few moments to thoroughly read the instructions and familiarize yourself with all the operational aspects of your new Soleus Air Car Air Purifier.

For your own records, please attach a copy of your sales receipt to this manual. Also, write the store name/location, date purchased, and serial number below:

Store Name: _____

Location: _____

Date Purchased: _____

Serial Number (located on back of unit): _____

IMPORTANT INSTRUCTIONS

When using this electric unit, basic safety precautions should always be followed to reduce the risk of fire, electric shock, and injury to persons, including the following:

1. Read ALL instructions before using this unit.
2. Plug the purifier directly into a 100V-240V electrical outlet.
3. The voltage of the automobile power supply must conform to the product specified voltage (DC12V), otherwise it will damage the product
4. Do not place the purifier in the car airbag and other areas affecting driving safety.
5. Do not expose the purifier to excessive heat or humidity. This could cause damage to the electrical components.
6. Do not immerse with any type of liquid. Do not use near water.
7. The purifier should kept out of the reach of children. Close supervision is necessary when the purifier is use by or near children.
8. To reduce the risk of fire or explosion, do not store or use gasoline or other flammable vapors or liquids in the vicinity of the purifier.
9. Do not operate this or any appliance with a damaged cord, if the unit malfunctions, or if it has been dropped or damaged in any manner. Connect to polarized outlets only.
10. Do not cover the cord or place near heat sources. Keep the cord away from high traffic areas, and do not submerge in water.
11. Unplug the purifier before moving or servicing, do not adjust the purifier when driving.
12. To reduce the risk of fire or electric shock, do not use this purifier with any solid-state speed control device.
13. To disconnect, grip the plug and pull from wall outlet. Never pull on the cord to unplug.
14. There may be a slight smell which is similar to the soil smell after the rain when using this product, this is normal circumstance and the purifier is function properly.
15. Be extra cautious when children and infants are around during use.

PACKAGE CONTENTS

- SoleusAir Car Air Purifier
- Operating Instructions
- Car Cig-jet Power Adaptor
- Mounting Bracket
- Home-use Stand
- Home-use Power Adaptor

SPECIFICATIONS

Model Number	KJ60F-C01
Power Consumption (Watts)	10 W
Rated Voltage	DC 12V ---
Amperage	0.8 A
Noise Level	≤36 dB(A)
Particulate CADR	35 CFM
Product Weight	3.8 lbs.
Product Dimensions (W x D x H)	14.3'' x 7'' x 2.7''

PRODUCT DIAGRAM

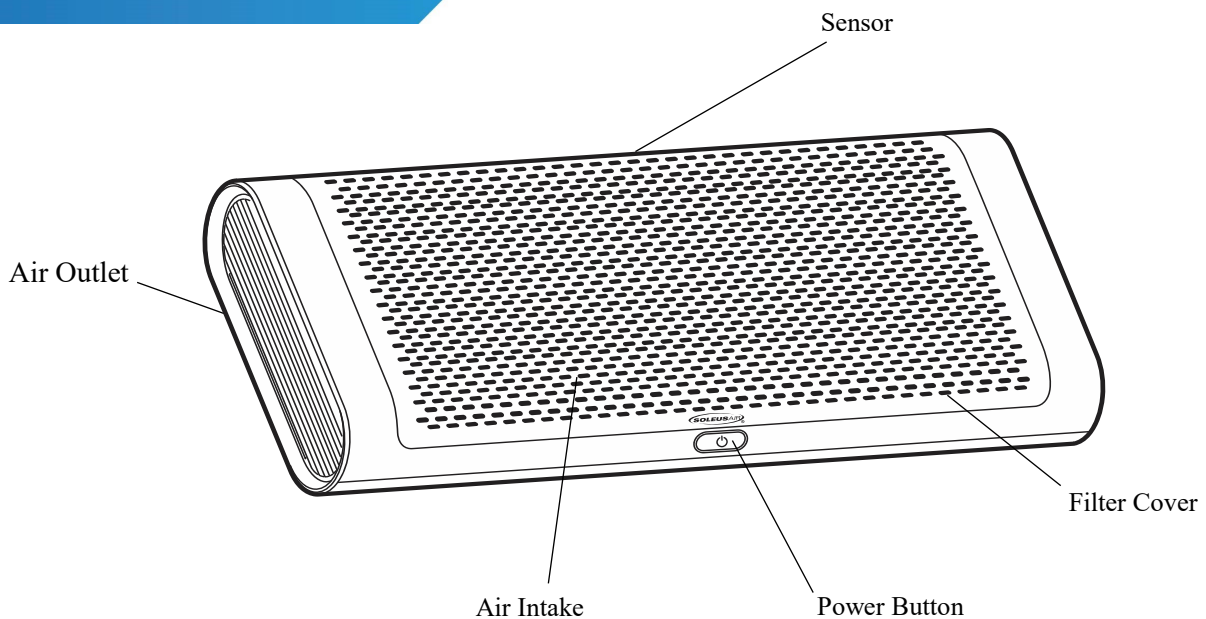

INSTALLATION

You can install this product in the following locations:

- **Headrest Installation:** When installing the product, make sure that the power button is upward and the product is fastened to the bracket with the air intake facing outside. Hold the product close to the back of the pillow and wrap the tie around the pillow, then tighten the product.

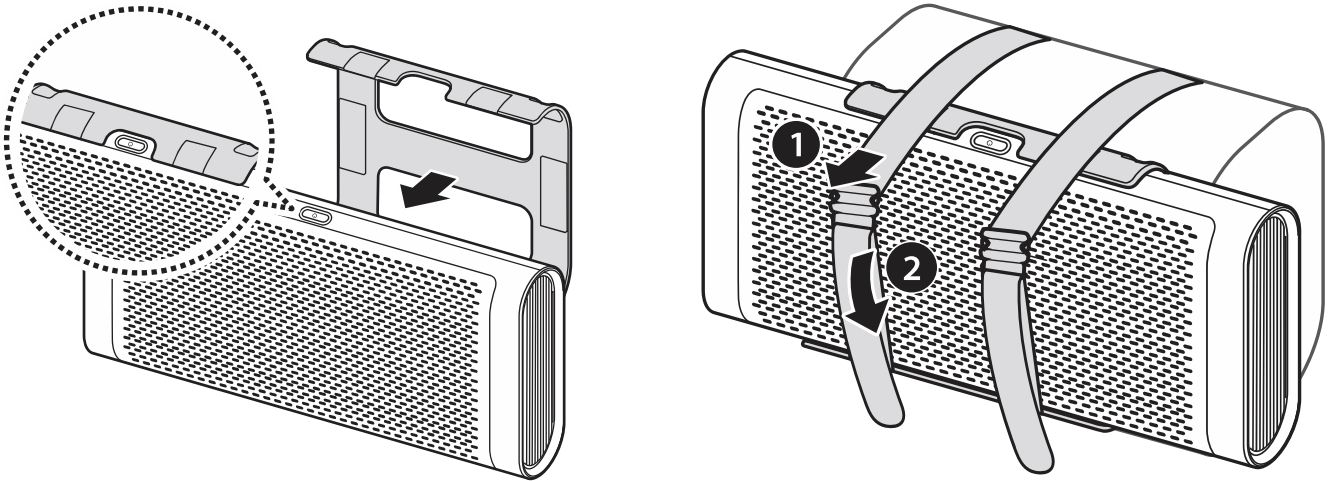

- **Tie Rod Installation:** After installing the bracket, adjust the length of the tie rope, cross the two straps on the bracket on the metal pole of the pillow and then fasten them.

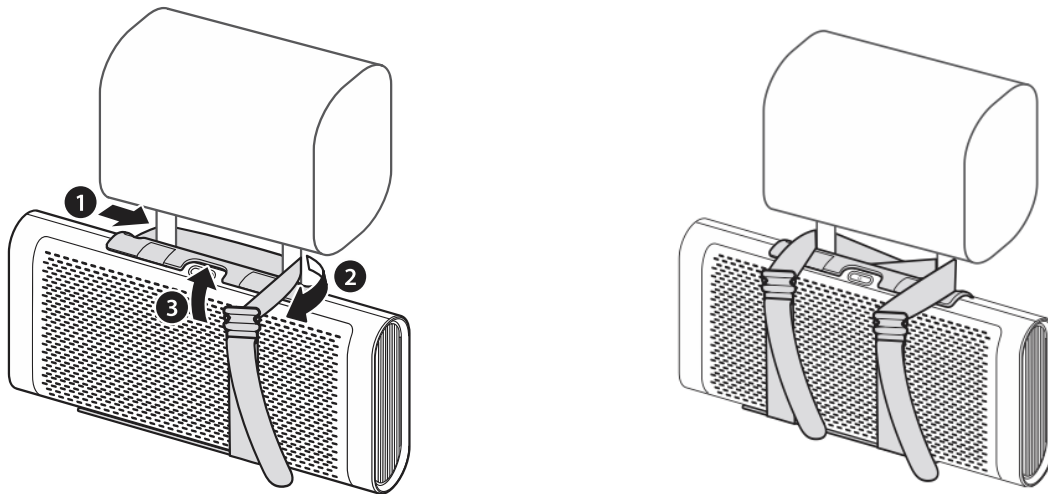

- Once the unit is positioned, plug in the power at the bottom of the unit and insert the cig-jet to the vehicle charger.

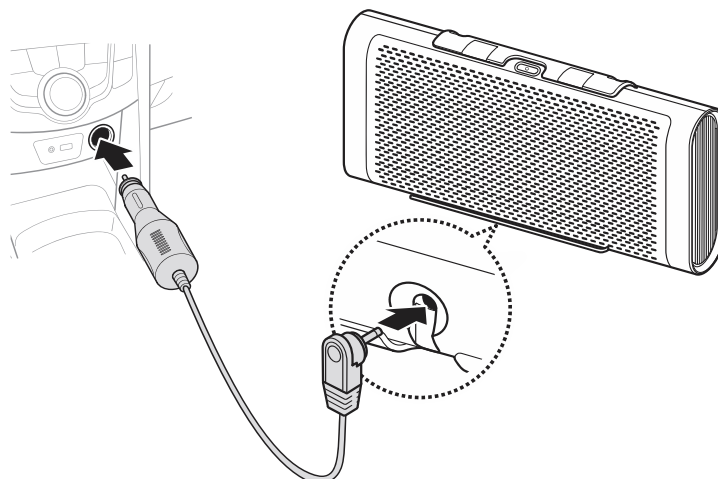

OPERATION

- 1) **Power On and Off** - Press the power button once to manually turn the unit on. Press and hold the power button over 3 seconds to turn the unit off.
- 2) **Fan Speed/Mode Selection** — Press the power button repeatedly to cycle between the different fan speed/mode, the rotation is: Auto/Low/Mid/High, the buzzer will ring with each press of the power button.
- 3) **Indicator light** — When the unit is on, yellow, blue and green lights will indicate the current air quality. When in auto mode, the unit will automatically change the fan speed based on the air quality as shown below:

Indicator Color	Air Quality	Fan Speed
Yellow	Poor	Auto High Speed
Blue	Fair	Auto Medium Speed
Green	Good	Auto Low Speed

- 4) **Filter Replacement and Reset** — When the filter needs to be changed, a red light will keep flashing and the unit will stop working. Press and hold the power button over 6 seconds to reset the filter. Hold the power button over 15 seconds to enter the filter replacement self-test mode, the indicator will flash in red and the buzzer will ring.

Note: The unit will automatically turn off after a continuous working for 6 hours.

Note: For faster air purification, keep the windows closed when using this product.

Note: The package comes with an adapter and a stand for use of the purifier at home.

CLEANING & MAINTENANCE

Note: Make sure power is off and the power cord is not plugged into an electrical outlet prior to performing any maintenance on the unit

1. Wipe the purifier down with a damp cloth for most efficient operation.
2. Air dry the unit completely before use.
3. Never use abrasive cleaning agents or solvents. This may cause damage or deterioration to the surface of the unit.
4. Do not immerse the purifier in any form of liquid. Do not allow water to drip on or into the purifier motor housing.

STORAGE

If the purifier will not be use for a long period of time, store it in a cool and dry location. To prevent dust and dirt build-up, use the original packaging to store the unit.

FILTER REPLACEMENT

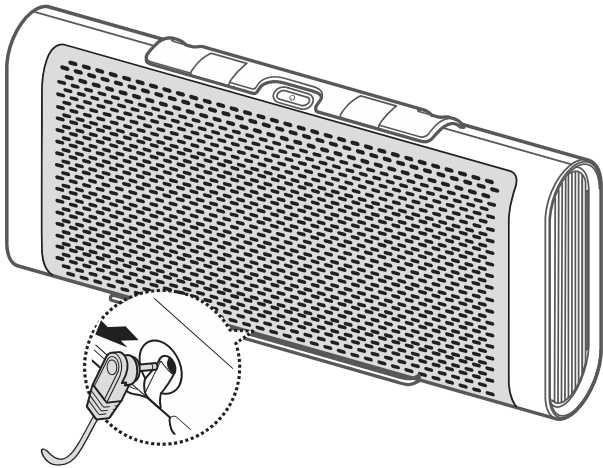

1. Disconnect the power supply

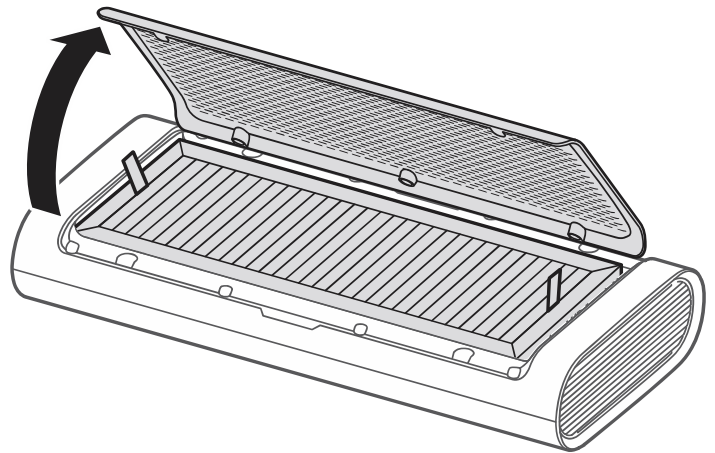

2. Open the lid cover

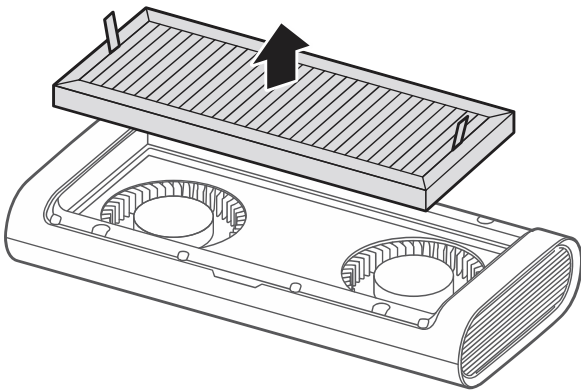

3. Pulling the straps on the side to remove the old filter

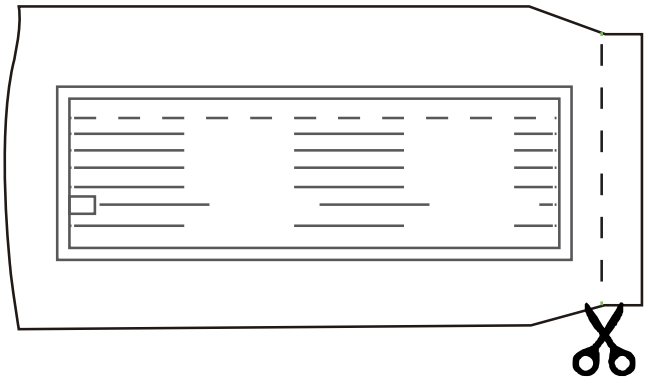

4. Remove the plastic bags from the new filter

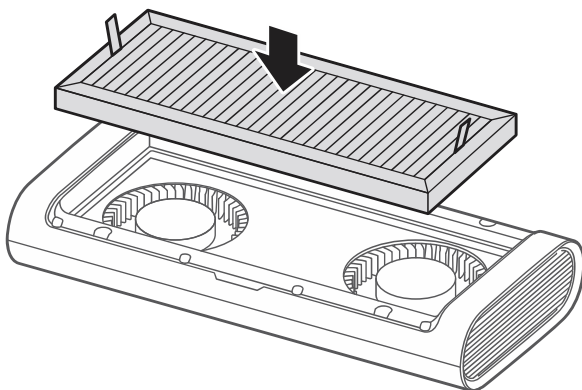

5. Insert the new filter to the air purifier
** Please make sure the straps are facing upward.*

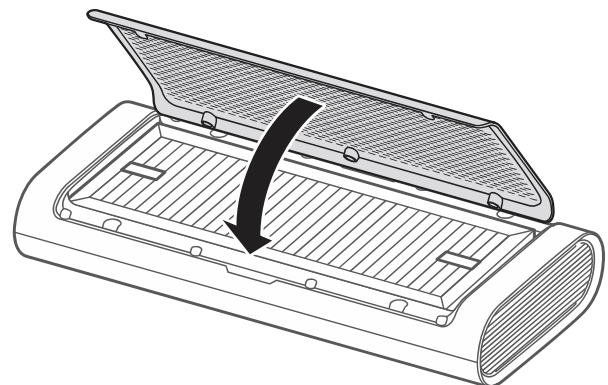

6. Close the lid cover
** The unit will not start if the lid is uncovered.*

Note: The filter will need to be changed periodically as dirt visible accumulates. This can vary greatly depending on air quality and amount of use. When the filter is dirty, replace it with a Soleus Air Replacement Filter.

***Replacement filter is available at acsaddle.com**

CAUTION: DO NOT OPERATE THE AIR PURIFIER WITHOUT A FILTER.

PROBLEM	SOLUTION
The purifier is not turning on and the indicator light is off.	<ul style="list-style-type: none"> • Make sure the car is started. • Make sure the plug is connected to the car cigarette lighter socket. • Check the power cord and make sure it is connected properly. • Make sure the lid is covered properly.
The purifier fan doesn't work	<ul style="list-style-type: none"> • Check the power cord and make sure it is connected properly. • Check if there is any obstacles blocking the air intake and air outlet. • Check if the filter is installed properly.
Power button doesn't work	<ul style="list-style-type: none"> • Check the power cord and make sure it is connected properly. • Please contact customer service at (877)-976-5387
Replacement filter is not applicable	<ul style="list-style-type: none"> • Make sure a SoleusAir replacement filter is used. • Check if the filter is installed properly. • Make sure the packing plastic bag is removed. • Make sure there is no objects blocking filter placement.
The air volume is getting obviously smaller	<ul style="list-style-type: none"> • Check if there is any obstacles blocking the air intake and air outlet. • Clean or replace the filter.
The indicator flashes in red continuously	<ul style="list-style-type: none"> • Check if there is any obstacles blocking the sensor. • Clean the sensor area. • If the indicator is still flashing red, please contact customer service at (877)-976-5387

One Year Limited Warranty

Soleusair West warrants the accompanying Soleusair air purifier to be free of defects in material and workmanship for the applications specified in its operation instruction for a period of ONE (1) year from the date of original retail purchase in the United States.

If the unit exhibits a defect in normal use, Soleusair West will, at its option, either repair or replace it, free of charge within a reasonable time after the unit is returned during the warranty period.

As a condition to any warranty service obligation, the consumer must present this Warranty Certificate along with a copy of the original purchase invoice.

THIS WARRANTY DOES NOT COVER:

- Damage, accidental or otherwise, to the unit while in the possession of a consumer not caused by a defect in material or workmanship.
- Damage caused by consumer misuse, tampering, or failure to follow the care and special handling provisions in the instructions. This includes dents, accidental or otherwise, to the base and head of the unit.
- Damage to the finish of the case, or other appearance parts caused by wear.
- Damage caused by repairs or alterations of the unit by anyone other than those authorized by Soleusair West.
- Freight and Insurance cost for the warranty service.

ALL WARRANTIES, INCLUDING ANY IMPLIED WARRANTY OF MERCHANT ABILITY ARE LIMITED TO ONE-YEAR DURATION OF THIS EXPRESS LIMITED WARRANTY. **SOLEUSAIR WEST** DISCLAIMS ANY LIABILITY FOR CONSEQUENTIAL OR INCIDENTAL DAMAGES AND IN NO EVENT SHALL SOLEUSAIR WEST'S LIABILITY EXCEED THE RETAIL VALUE OF THE UNIT FOR BREACH OF ANY WRITTEN OR IMPLIED WARRANTY WITH RESPECT TO THIS UNIT.

This warranty covers only new products purchased from our authorized dealers or retailers. It does not cover used, salvaged, or refurbished products.

As some states do not allow the limitation or exclusion of incidental or consequential damages, or do not allow limitation on implied warranties, the above limitations and exclusions may not apply to you. This warranty gives you specific legal rights, and you may also have other rights that vary from state to state.

For Technical Support & Warranty Service

Please Call (877) 976-5387

Or visit www.soleusairwest.com