

WARRANTY

One Year Limited Warranty

Soleus Home Comfort warrants the accompanying Soleus Air Y cvgt Eqqrqt to be free of defects in material and workmanship for the applications specified in its operation instruction for a period of ONE (1) year from the date of original retail purchase in the United States.

If the unit exhibits a defect in normal use, Soleus Home Comfort will, at its option, either repair or replace it, free of charge within a reasonable time after the unit is returned during the warranty period.

As a condition to any warranty service obligation, the consumer must present this Warranty Certificate along with a copy of the original purchase invoice.

THIS WARRANTY DOES NOT COVER:

- Damage, accidental or otherwise, to the unit while in the possession of a consumer not caused by a defect in material or workmanship.
- Damage caused by consumer misuse, tampering, or failure to follow the care and special handling provisions in the instructions.
- Damage to the finish of the case, or other appearance parts caused by wear.
- Damage caused by repairs or alterations of the unit by anyone other than those authorized by Soleus Home Comfort.
- Freight and Insurance cost for the warranty service.
- Filter and Accessories

ALL WARRANTIES, INCLUDING ANY IMPLIED WARRANTY OF MERCHANT ABILITY ARE LIMITED TO ONE-YEAR DURATION OF THIS EXPRESS LIMITED WARRANTY. **SOLEUS HOME COMFORT** DISCLAIMS ANY LIABILITY FOR CONSEQUENTIAL OR INCIDENTAL DAMAGES AND IN NO EVENT SHALL SOLEUS HOME COMFORT'S LIABILITY EXCEED THE RETAIL VALUE OF THE UNIT FOR BREACH OF ANY WRITTEN OR IMPLIED WARRANTY WITH RESPECT TO THIS UNIT.

This warranty covers only new products purchased from our authorized dealers or retailers. It does not cover used, salvaged, or refurbished products.

As some states do not allow the limitation or exclusion of incidental or consequential damages, or do not allow limitation on implied warranties, the above limitations and exclusions may not apply to you. This warranty gives you specific legal rights, and you may also have other rights that vary from state to state.

For Technical Support and Warranty Service

Please Call (888) 876-5387

Or Write To:

Soleus Home Comfort
17911 East Ajax Circle
City of Industry, CA 91748
www.soleushomecomfort.com



WD1-02-01 Hot and Cold Water Cooler Operating Instructions



Thank you for choosing a Soleus Air Water Cooler. This owner's manual will provide you with valuable information necessary for the proper care and maintenance of your new product. Please take a few moments to thoroughly read the instructions and familiarize yourself with all the operational aspects of your new water cooler.

For your own records, please attach a copy of your sales receipt to this manual. Also, write the store name/location, date purchased, and serial number below:

Store Name: _____

Location: _____

Date Purchased: _____

Serial Number (located on back of unit): _____

IMPORTANT SAFETY INSTRUCTIONS

When using electrical appliances, basic safety precautions should be followed to reduce the risk of fire, electric shock, and injury to persons or property. Read all instructions before using any appliance.

1. Do not let hot water touch bare skin. Keep combustible material such as furniture, bedding, pillows, clothes, and/or papers away from the back of the unit.
2. Do not operate this, or any other appliance, with a damaged power cord. No other appliance should be plugged into the same outlet. Be sure that the plug is fully inserted into the outlet.
3. Do not run the power cord over carpeting or other heat insulators. Do not cover the cord. Keep cord away from high traffic areas, and do not submerge in water.
4. We do not recommend the use of extension cord as it may overheat and cause a risk of fire.
5. Exercise caution and use reasonable supervision when the appliance is used by or near children.
6. Do not use your water dispenser outdoors. Place the water dispenser away from direct sunlight and make sure that there is at least 4 inches (10cm) of space between the back of your unit and wall. Keep a minimum of 2 inches (5cm) on each side of your unit free.
7. Do not use this product to dispense anything other than water.
8. To avoid a hazard due to instability of the appliance, it must be placed on even and flat surface.
9. If the supply cord is damaged, the manufacturer or its service agent or a similarly qualified person must replace it in order to avoid a hazard.
10. This water cooler must be positioned so that the plug is accessible.
11. Disconnect the plug from the outlet when not in use.
12. Remove power plug or disconnect from the main power source before servicing the appliance.

PLEASE SAVE THESE INSTRUCTIONS.

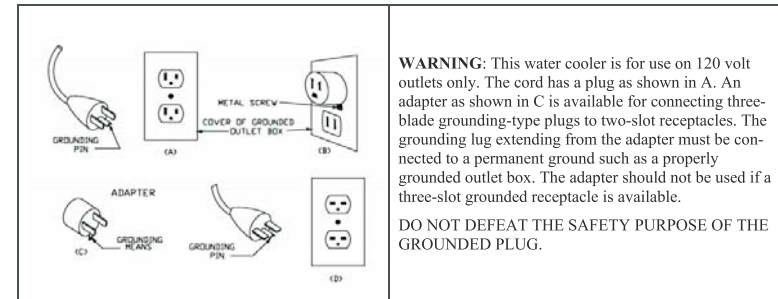

TECHNICAL SPECIFICATIONS

Model Number	WD1-02-01
Power Supply	115V (60Hz)
Electrical Rating	5.8 Amps, 590 Watts
Refrigerant and Quantity	R134a, 1.10oz
Design Pressure (High Side)	232 psig
Design Pressure (Low Side)	88 psig
Compatible Temperature	50°F - 100.4°F 10°C - 38°C
Product Dimensions	11.75" W x 13" D x 33.5" H
Product Weight	24.9 lbs

PRODUCT DIAGRAM

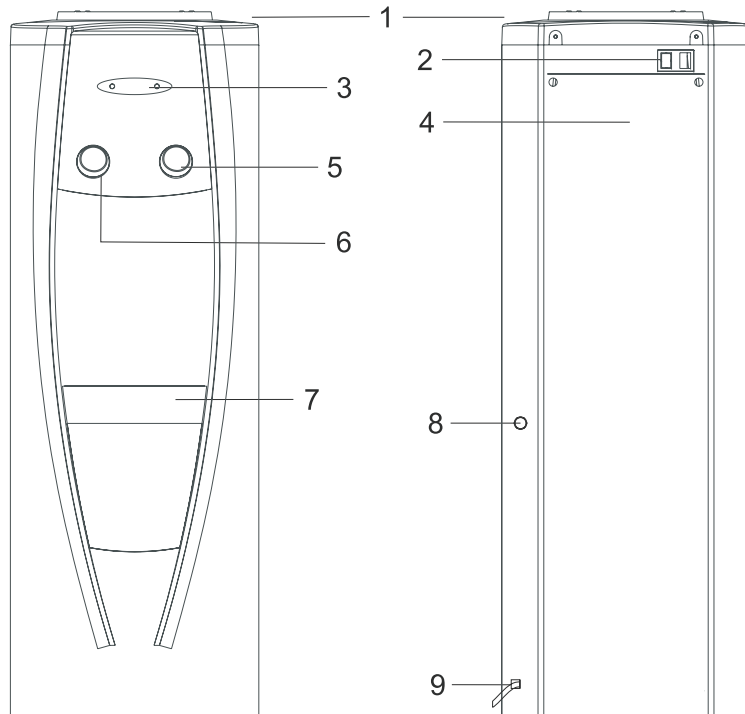

PRODUCT DIAGRAM

1. Top of Water Cooler
2. Power Switch
3. LED Status Lights
4. Data Plate
5. Cold Water Faucet
6. Hot Water Faucet
7. Drip Tray
8. Drain Plug
9. Electrical Power Cord and Plug

LED INDICATOR LIGHTS

RED: When the red LED indicator lights up the water is being heated inside the water dispenser.

GREEN: When the green LED indicator lights up the water is being cooled inside the water dispenser.

UNPACKING THE WATER COOLER

1. Cut and remove the straps from the box. **DO NOT** turn the box upside down, or lay it on its side. The bottom of the box is separate from the top section. Lift straight up on the top box section to remove the top box section. Remove the Styrofoam packaging and plastic bag. Lift the water cooler off the bottom of the box. Wipe it clean if necessary.
2. Place the machine on a hard, flat surface. Make certain the unit is level. The unit should not be close to direct sunlight or other source of heat.
3. It is best to place the water cooler in an area with good air circulation. Make sure there is at least 4 inches (10cm) of space between the back of your water cooler and the wall. Keep a minimum distance of 2 inches (5cm) on each side of your water cooler.

WARNING: The drain cap on the back of the unit may become loose during shipping. Tighten the drain cap before you start to operate the unit. If the drain cap is loose, the unit may leak and cause floor damage.

NOTE: Please do not use the hot water dispenser until the unit is plugged and a water bottle has been placed on top. Failure to follow these instructions may permanently disable the hot water dispenser.

WATER COOLER OPERATION

After the water bottle has been connected to the top of the water cooler, the unit is ready for use. Turn the power switch on the back of the unit to ON. The water cooler will start running. Make sure both the cold and hot water switches on the back of the unit are in the ON position.

To Use the water cooler, press down on the either the cold or hot water dispensers. Doing this will dispense water. The hot water dispenser has a child safety feature that prevents small children from possibly being burned by hot water. To use the hot water dispenser, press down on the red dispenser while holding the small button at the bottom of the dispenser at the same time.

CLEANING & MAINTENANCE

1. To avoid accidents, turn off and unplug the water cooler from the outlet before cleaning.
2. A soft damp cloth may be used to clean the surface of the water cooler. When necessary, a mild detergent may be used. DO NOT use erosive chemical solvents to clean the unit, as this may damage the surface of the water cooler.
3. DO NOT pour water on the exterior of the unit to avoid getting the internal electrical system damp. DO NOT immerse the unit in water when cleaning.
4. Keep the water cooler 6 inches (15cm) away from the wall so it can work properly. Make certain all ventilation openings are clear of obstruction.
5. Do not damage the heating or cooling system, paying particular attention to the black condenser or heat radiator on the back of the water cooler.
6. If you will not use the water cooler for a long period of time, please unplug the power cord and drain the water cooler. Drain the water from all faucets, then remove the drain cap on back and allow it to drain. Make certain the drain cap is fastened tightly when finished.

TROUBLESHOOTING

Please check the troubleshooting chart below. It includes several common problems, which you can correct at home, making a customer service call unnecessary.

Problem	Possible Cause	Remedy
Unit does not dispense hot and cold water.	Unit is unplugged.	Plug the power cord into an outlet.
	The Power Switch is turned off.	Turn on the Power Switch
	Damaged water dispenser	Replace the dispenser.
Unit does not dispense cold water.	Over consumption of cold water in a short time.	Wait a moment for the water to cool.
	System Malfunction	Contact Soleus Air for service
	The ventilation around the unit is insufficient.	Space the unit from the wall by more than 5.875 inches.
Unit does not dispense hot water.	The temperature of water in the water bottle is too high. (When the bottle is exposed to direct sunlight for a long time.)	Place the water bottle in a cool location out of direct sunlight.
	Over consumption of hot water in a short time.	Wait a moment for the water to heat.
Unit is noisy during operation.	System Malfunctions	Contact Soleus Air for service
	The appliance is not level.	Place the unit on a level, flat surface.
Water leaks from the faucet.	Unit is touching other objects.	Move the unit away from other objects.
	The top portion of the faucet has become loose.	Tighten the top threaded portion of the faucet.
	The faucet has been damaged.	Call the customer service telephone number to repair the faucet.